

Cockpit dodgers or weather cloths

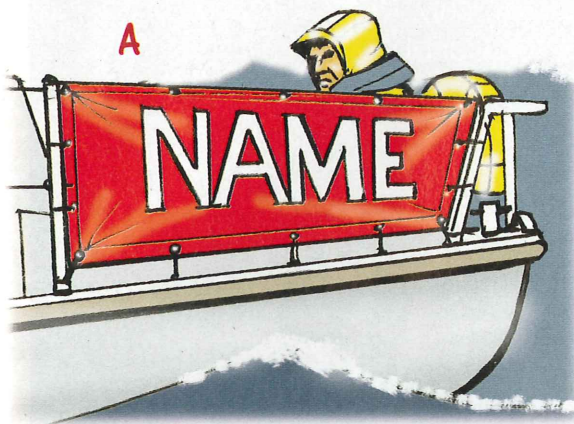

A. Cockpit dodgers, or weather cloths, keep some of the wind and spray off at sea and provide a degree of privacy when in harbour. They also provide a good place to display the boat's name, which makes identification easier. You can sew your own, or buy off-the-peg ones, which are cheaper than custom-made ones.

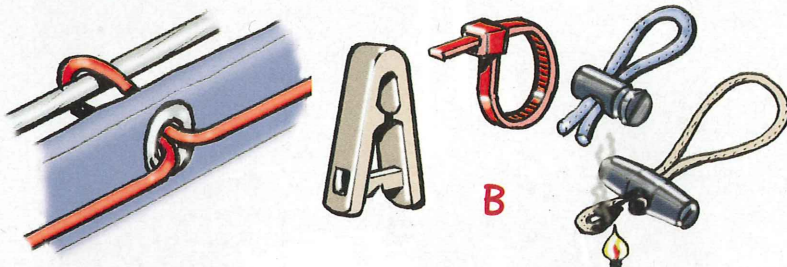

B. They can be fixed on in all sorts of ways. Simple in-and-out lashings keep the tension even and can be released easily, but a series of knots is more secure. Various plastic clips, ties, clamps and toggles also work well.

C. One useful addition is to sew on a couple of pockets, especially if there are no lockers built into the boat's cockpit coamings.

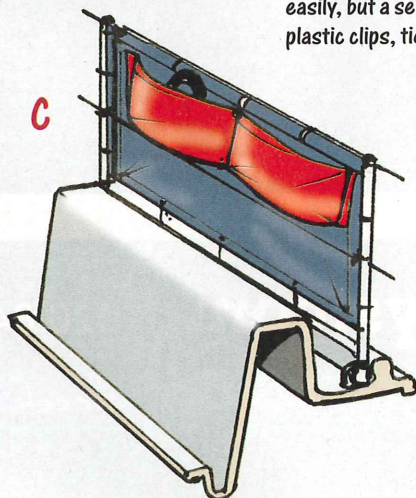

D. Sometimes it can be awkward to swing a large top-acting winch handle without grazing your knuckles on the canvas. On some boats they get around this by having cut-outs in the dodgers. The holes can then be covered with flaps, or by sewing on a generously-proportioned gusset.

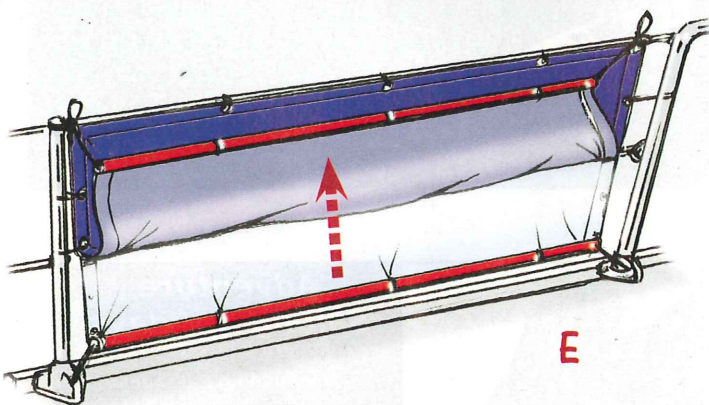
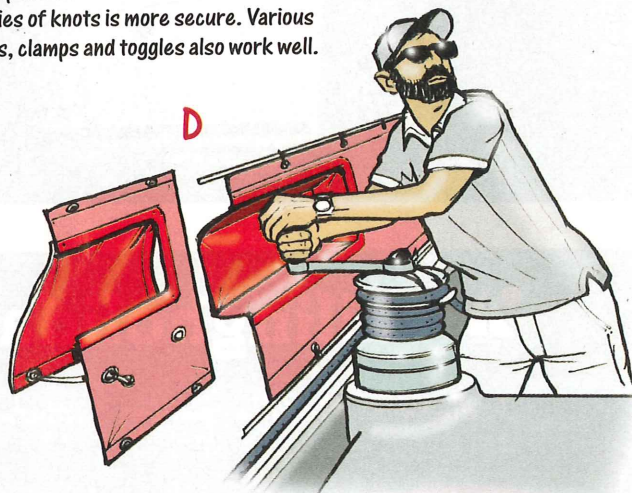

E. A plastic pipe fixed along the bottom reduces the number lashings needed. It can be raised easily to let in a cooling breeze, or let out green water. Some people use weak fixings at the bottom that'll give way if you scoop up a wave.

F. A bag, formed from a doubled-up dodger, can hold all the MOB gear. Then, a quick pull on the rip-cord releases the top edge, and the whole lot drops.

